

Flat Pattern view
SCALE: 1:10

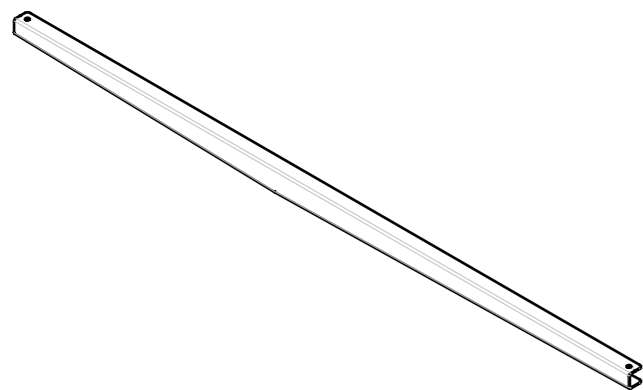
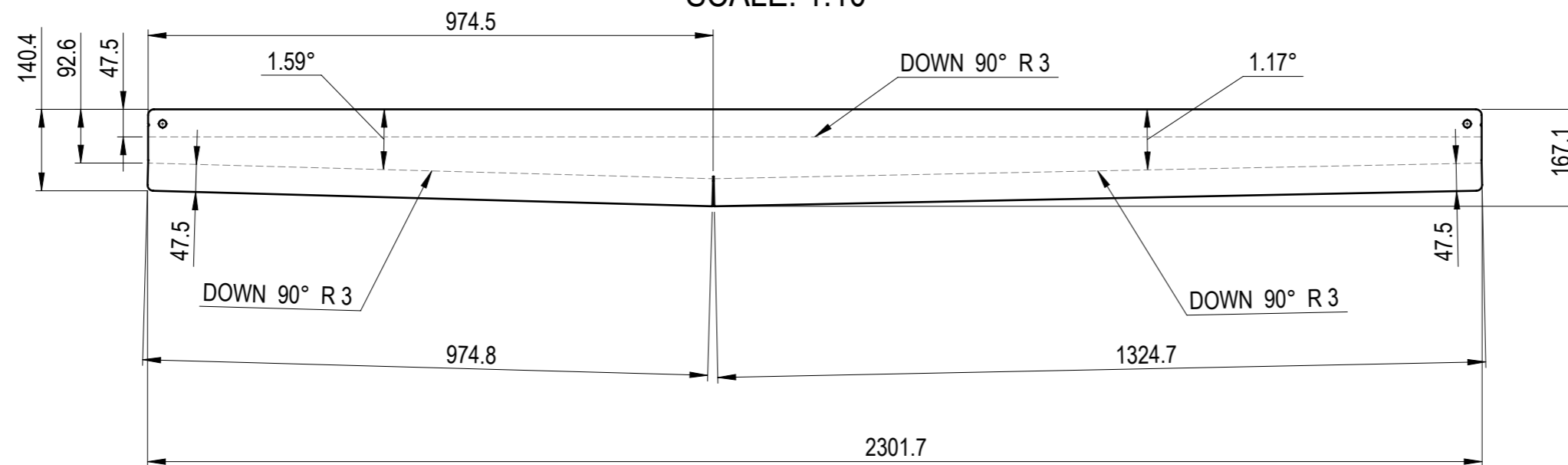

SHEET METAL INFORMATION	
Length, mm	2301.7
Width, mm	167.1
Thickness, mm	3
Inside Bend Radius, mm	3
K-Factor	0.5
No. of Bends	3

Other dimensions from .DXF file.

WEMPS ENGINEERING SERVICES	MATERIAL	WEIGHT	DEBURR AND BREAK SHARP EDGES		REVISION	DATE
	S355	8.260 Kg	DO NOT SCALE DRAWING			6/4/2025
	SURFACE PROTECTION	MACHINING	THERMAL CUTTING	WELDING	SCALE	FORMAT
	HDG + G3.02 EN ISO 12944	ISO 2768 mK	ISO 9013 221	ISO 13920 BF	1:4	A3
	NAME	SIGNATURE	PART NO.			
Designed by	D. Dislers		105-09100-83			
Drawn by	D. Dislers		DESCRIPTION			
Technical ref.			U-Profile 9			SHEET 1/1